

---

# RUD TECDOS TM

## Operating Instructions Turning table for prototype tools

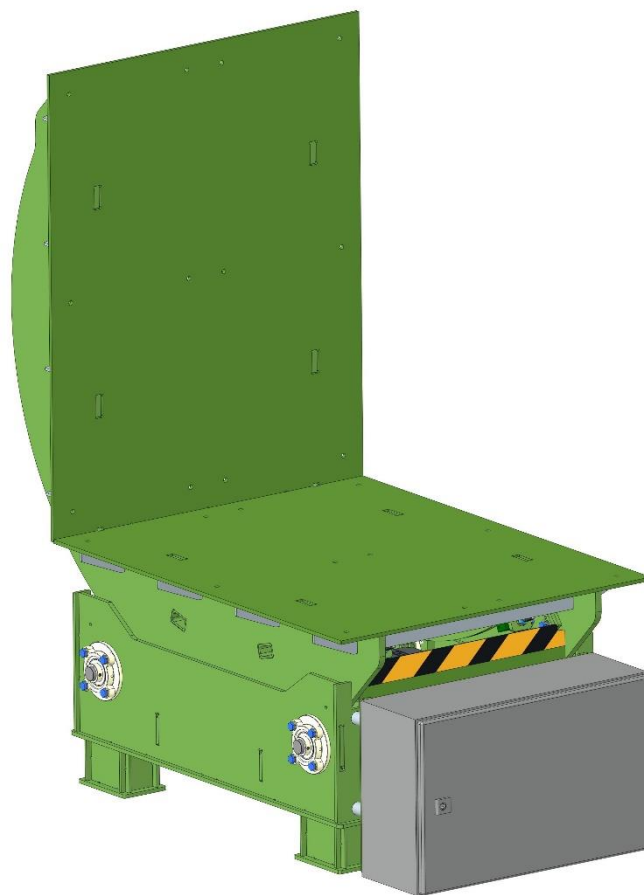

## Content:

1. Foreword	Page 3
1.1 General information	Page 3
1.2 Main components of the TECDOS TM	Page 4
1.2.1 Overview display	Page 4
1.2.2 Detailed illustration of base frame	Page 5
1.3 Operational limits of the TECDOS TM	Page 6
1.3.1 Intended use	Page 6
1.4 TECDOS TM personnel	Page 6
1.4.1 Operators	Page 6
1.4.2 Staff involved with transportation	Page 6
2. Safety Instructions	Page 7
2.1 Explanation of symbols and instructions	Page 7
2.2 General information	Page 7
2.3 Maintenance and servicing	Page 8
3. Description	Page 9
3.1 General information	Page 9
3.2 Functional description	Page 9
4. Commissioning	Page 11
4.1 Transportation	Page 11
4.2 Installation location and space requirement	Page 11
4.3 Commissioning the TECDOS TM	Page 12
4.4 Accident or fault procedure	Page 13
5. Handling the TECDOS TM	Page 14
5.1 Loading the TECDOS TM	Page 14
5.2 Turn-over	Page 15
5.3 Servicing prototype tools on the TECDOS TM	Page 16
5.4 Unloading the TECDOS TM	Page 16
5.5 Lubricating instructions and recommended lubricants	Page 16
5.6 Setting and tensioning the chain strands	Page 17
6. Replacing worn parts	Page 18
6.1 Replacing the chain	Page 18
6.2 Replacing the track wheels	Page 18
Appendix: Centre of gravity	Page 19

## 1. Foreword

### 1.1 General information

This Instruction Manual will help you use the RUD TECDOS TM safely, properly and economically. By applying the information in this Instruction Manual, you will:

- increase the reliability and the service life of the RUD TECDOS TM,
- avoid dangers and
- reduce repairs and system down times.

**This Instruction Manual must:**

- **always be available at the location at which the machine is being used**
- **be read and complied with by everyone who works with the RUD TECDOS TM.**

The RUD TECDOS TM has been manufactured using the latest technological developments and the approved technical safety regulations. However, there may be a risk to life and limb for the user or a third party, or a risk of physical damage to the TECDOS TM and other equipment, if material is not processed correctly, or if the TECDOS TS is not used correctly.

Spare parts must meet the technical requirements defined by RUD Ketten. This is guaranteed in the case of original spare parts, as they undergo constant quality control supported by an ISO 9001-certified quality management system. Third party spare parts can in some circumstances change the system's properties, as defined in the design phase, and cause major defects for which RUD Ketten shall accept no liability.

Use suitable workshop equipment for maintenance. Only personnel authorised by the manufacturer can perform technically sound maintenance or repair.

This Instruction Manual has been created with the greatest possible care. It contains 19 pages of text. However, if you need additional information, please contact:

**RUD Ketten**  
**Rieger & Dietz GmbH u. Co. KG**  
**Friedensinsel**  
**73432 Aalen/Germany**  
**Tel. +49 7361 504-1457**  
**Fax +49 7361 504-1523**  
**[salesfa@rud.com](mailto:salesfa@rud.com)**  
**[www.rud.com](http://www.rud.com)**

© 2023 RUD Ketten

These instructions are protected by copyright. The company RUD Ketten retains the right to make changes.

## 1.2 Main components of the TECDOS TM

### 1.2.1 Overview display

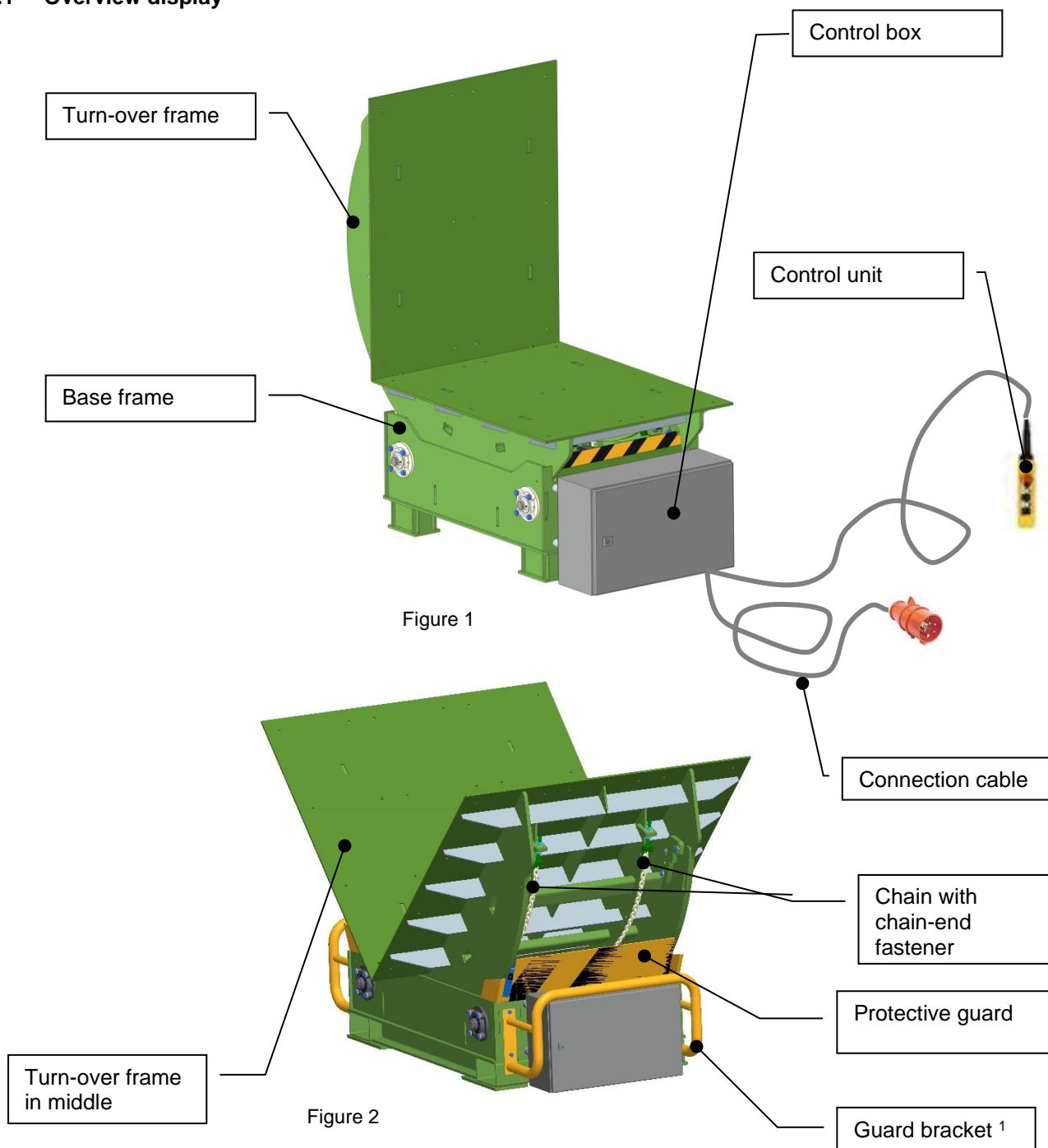

The illustrations are functional or indicative. The TECDOS TM08/10-5 (Figure 1) and TECDOS TM13/13-10 (Figure 2) are illustrated here.

<sup>1</sup> optional accessories

1.2.2 Detailed illustration of base frame

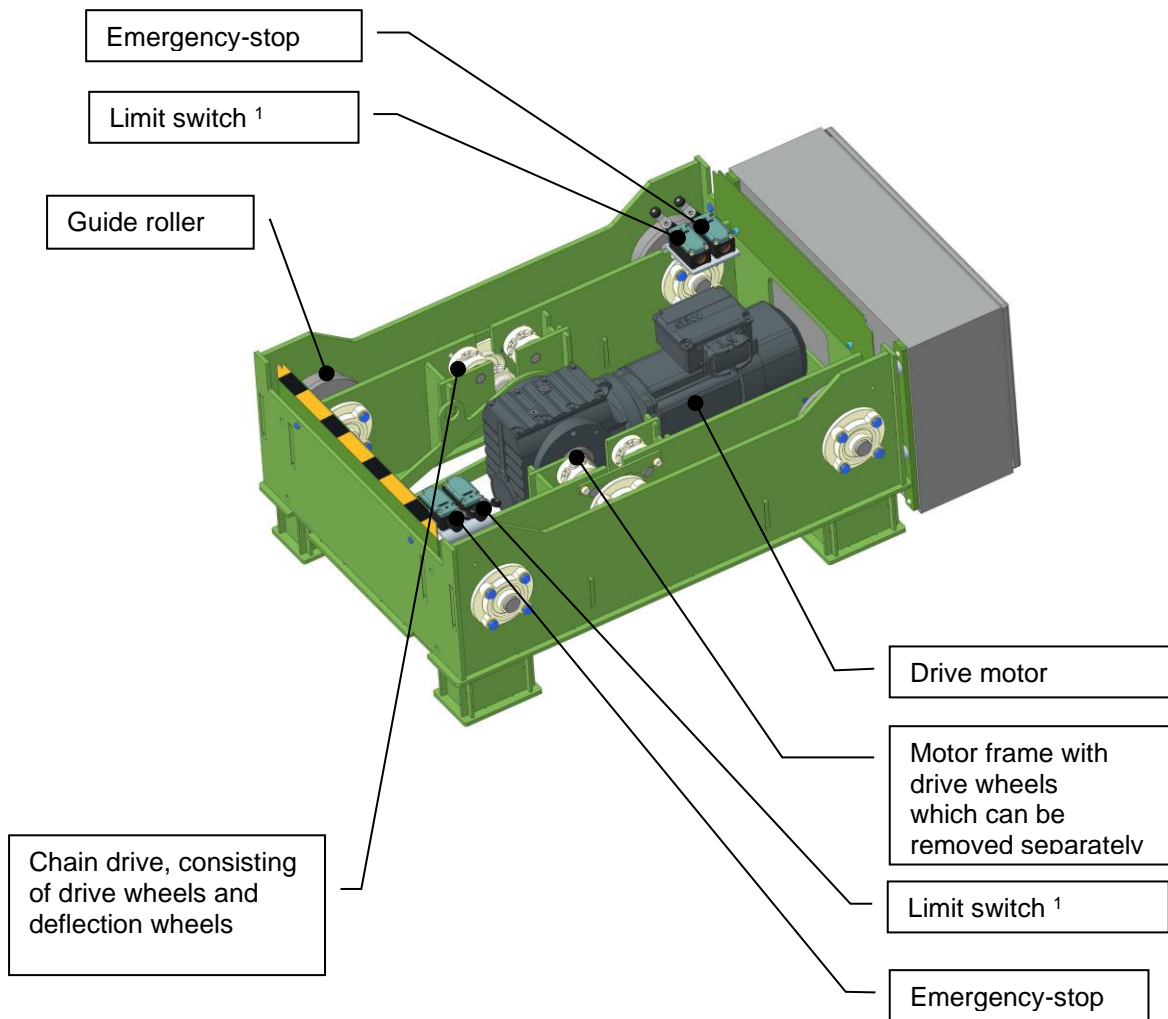

Figure 3

The TECDOS TM is supplied as a fully assembled function-tested unit. It is ready for use immediately after its connection cable has been connected to a power supply (TM 08/10-5, TM 08/13-10, TM 13/13-10, TM 15/18-16, TM 20/20-20: CEE plug 16 A, 400 V – 50 Hz) and the commissioning process has been carried out.

The electrical connection cable is 6 m long. The cable lengths for the control unit are:

- TM 08/10-5: 4 m
- TM 08/13-10: 4 m
- TM 13/13-10: 4 m
- TM 15/18-16: 8 m
- TM 20/20-20: 8 m

<sup>1</sup> Illustration is analogous, the TM 20/20-20 can contain up to three limit switches

---

## 1.3 Operational limits of the TECDOS TM

### 1.3.1 Intended use

The TECDOS TM is designed to rotate prototype tools safely through 90° without damaging them. Servicing and maintenance tasks can be performed on prototype tools when they are positioned at one of the two end positions on the turning frame. There is no need for operators to step onto the TECDOS TM to do so. The TECDOS TM can be used almost anywhere indoors. It can be moved easily from one location to another, using suitable handling equipment (for example, a forklift truck) or a crane. The TECDOS TM is usually installed in factory halls. It must not be used outdoors. Usual operating temperatures: between 10°C and 30°C.

## 1.4 TECDOS TM personnel

### 1.4.1 Operators

The TECDOS TM must only be used by operators who have the appropriate authorisation to move these loads. Operators must also have been properly instructed in how to use the TECDOS TM and their managers must ensure that they have read and fully understood these Operating Instructions.





### 1.4.2 Staff involved with transportation

If the TECDOS TM is to be transported with a forklift truck, the forklift truck driver must have the appropriate training certificates (forklift driver's licence).

Transportation by crane must only be performed by operators with the appropriate specialist training who also have permission to work with lifting gear, cranes and attachment fittings.

## 2. Safety instructions

### 2.1 Explanation of symbols and instructions

 <b>Warning!</b>	<p><b>Failure to comply with the relevant safety instructions can cause danger to life or considerable damage to property.</b></p>
 <b>Caution!</b>	<p><b>Failure to comply with the relevant safety instructions can result in unexpected events or situations.</b></p>
	<p><b>Warning of danger of crush injuries</b></p>
	<p><b>Warning of hazardous electrical voltage</b></p>

### 2.2 General information

These Operating Instructions describe the RUD TECDOS TM and how to use it. Compliance with these Operating Instructions is a requirement for problem-free operation and the meeting of any claims under warranty that might arise. You must read these Operating Instructions before using the TECDOS TM.

Compliance with these Operating Instructions is a requirement for operating the TECDOS TM safely and for ensuring that the specified features and performance are achieved. RUD Ketten accepts no liability for personal injuries or any damage to property and assets arising from failure to comply with these Operating Instructions. In such cases, any liability for material defects is excluded.

These Operating Instructions are to be read by properly qualified personnel who are tasked with operating, maintaining and repairing the TECDOS TM.

Ensure that replacement parts are disposed of safely and in a way that does not damage the environment.

Welding, naked flame and sanding tasks must not be performed on the machine.

Climbing up onto the TECDOS TM is not permitted!

For safety reasons, no unauthorised conversions or changes to the TECDOS TM are permitted.

RUD Ketten reserves the right to make changes to these Operating Instructions. All the information and instructions in these Operating Instructions have been created in accordance with generally recognised technical

regulations. However, the information and instructions are non-binding. Please contact RUD Ketten if you require additional information or clarification.

Generally applicable legal and other binding regulations for preventing accidents and protecting the environment, which supplement the Operating Instructions, must be noted and complied with. They describe how to handle hazardous materials or the provision and wearing of personal protective equipment, for example. The operating firm is liable for damage caused by a failure to comply with these Operating Instructions.

## 2.3 Maintenance and servicing

- Before starting maintenance work, the operator must ensure that no-one else is present in the machine's safety zone.
- The TECDOS TM must be inspected for damage by properly trained personnel every six months. The most important components to be checked are the chain, the chain-end attachments and the pocket wheels on the chain drive.
- For maintenance and cleaning, move the TECDOS TM to its middle position and use suitable lashings (e.g. RUD ICE-VSK with ICE fork-head ratchet chain tensioner) to secure it mechanically. Attach the lashing chains to ensure that the TECDOS TM is properly secured and cannot move in any direction (see Figure 4).

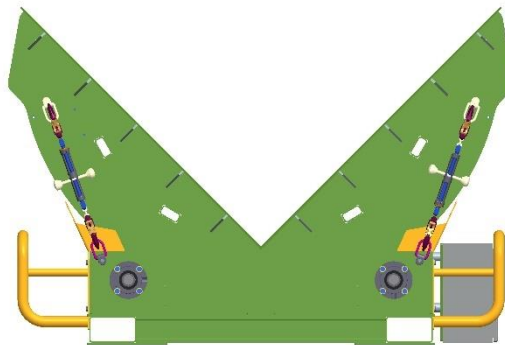

Figure 4

- Before starting maintenance work, block off access to the machine's working area to keep out unauthorised people. Display a sign that clearly states that maintenance work is in progress.

### Caution!

Disconnect the TECDOS TM from the power supply before starting maintenance work.

## 3. Description

### 3.1 General information

The TECDOS TM consists of the following main assemblies, as shown in the figures in section 1.2 of these Operating Instructions:

- the base frame, with integrated motor frame with chain drive,
- the turn-over frame used to rotate the prototype tool
- electrical control system, with a control unit and an electrical connection cable.

The TECDOS TM is supplied as a fully assembled function-tested unit. It is ready for use immediately after its connection cable has been connected to a power supply (see page 5).

#### Caution!

As the TECDOS TM consists of a number of individual, independent products, you must comply with further operating instructions and documents (for example, the electrical circuit diagram, operating instructions, drive motor data, the acceptance report for the control box, etc.), which are stored in the RUD-Cloud (a link to them will be sent by e-mail), in addition to these Operating Instructions.

#### Caution!

A high-performance TECDOS chain drive is used to power the turn-over frame. Comply with the general TECDOS component operating instructions for this chain drive.

### 3.2 Functional description

The TECDOS TM is designed to operate in a factory hall at ambient temperature. It is designed to rotate a prototype tool safely through 90°, without damaging the tool, for maintenance, assembly and disassembly.

The prototype tool is usually lifted onto the TECDOS TM by a crane. Ensure the prototype tool is lowered onto the TECDOS TM slowly and carefully, to prevent damage either to the turn-over frame or the prototype tool itself.

Next, the operator must check the area behind and around the TECDOS TM to make sure no-one else is present in the danger zone around the TECDOS TM (see Figure 6 in section 4.2). Once the operator is certain there is no-one else in the danger zone, they can press the buttons to start the rotation process (for more information on this, see section 4.3).

When the operator presses both buttons (using both hands) the TECDOS TM rotates as shown in the sequence of figures below (see Figure 5). The TECDOS TM initially moves slowly, then increases speed to the mid point of the process. It then slows down again in the end phase of the process. Other tasks can then be performed on the prototype tool.

Example of a rotation process:

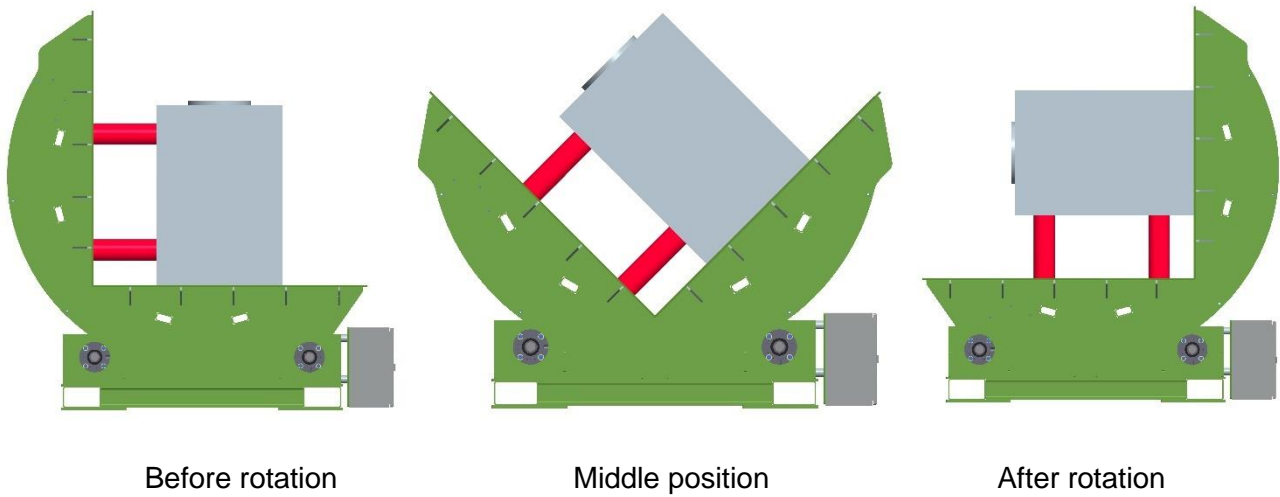

Figure 5

## 4. Commissioning

### 4.1 Transportation

The TECDOS TM must always be transported as a single unit, in its middle position (V-position). The TECDOS TM must be unloaded and disconnected from the power supply before it is moved. The cable with the plug on it and the control unit plus cable must be coiled up and attached to the TECDOS TM with cable ties.

For safety reasons, the TECDOS TM must only be transported when it is empty. This means there must not be a prototype tool on the TECDOS TM while it is being transported (unit weight: see table 2 on page 15).

The TECDOS TM has two fittings that enable it to be moved within the plant in two different ways:

- Tail lift for forklift
- Threaded holes for attachment points that are suitable for attaching a 4-strand stop chain.

Always use a means of transport that can safely handle the weight of the TECDOS TM (shown on the data plate). If a 4-strand hook chain is used to transport the TECDOS TM, use edge protectors to prevent the chain from damaging the edges of the machine.

Comply with all the general health and safety regulations stated in DGUV R 500 or local equivalent for working with handling equipment and lifting gear. Areas below suspended weights must also be secured appropriately.

### 4.2 Installation location and space requirement

The installation site must have a clean, dry, level horizontal surface, suitable for a load equal to at least the TECDOS TM's own weight plus the total operating load. The workplace must have adequate lighting. The installation site must be close to a CEE 16 A, 32 A or 63 A 400 V – 50 Hz socket (depending on the size of the TM). The TECDOS TM must be installed under cover (a roof) to protect it from the weather. The ceiling height should be at least three to four times greater than the machine table's length (see page 15 for dimensions). The installation site should be large enough to ensure the TECDOS TM can be surrounded by a safety zone in which the TECDOS TM stands at the centre, as shown in Figure 6. The highest levels of safety must be provided in this safety zone during rotation processes. The TECDOS TM operator must ensure no-one else is present in this safety zone when the machine is operating.

Size	Safety zone "Y" (minimum)
TM 08/10-5	2.4 – 3.9 m
TM 08/13-10	2,4 -3,9 m
TM 13/13-10	3,9 – 5,2 m
TM 15/18-16	4,5 - 6,0 m
TM 20/20-20	6,0 – 8,0 m

Table 1

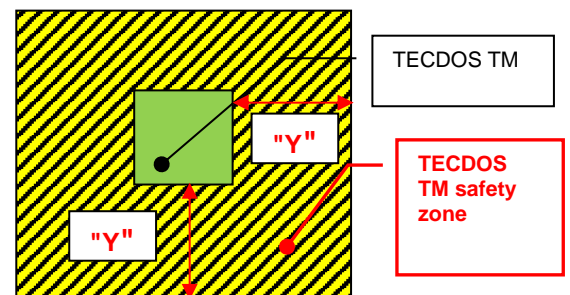
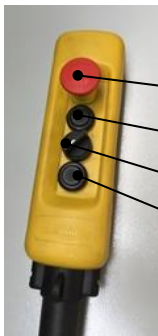

Figure 6

## 4.3 Commissioning the TECDOS TM

The TECDOS TM is ready for use immediately after its connection cable has been connected to a power supply (see page 5). First connect the connection cable and then switch on the main switch on the control cabinet.

The first time the machine is used, check whether it works properly under no load and familiarise yourself with how the control unit works. Check that all the buttons for the TECDOS TM are working properly. The control unit (or remote control) has buttons and switches with the following functions:



- Emergency stop button, rotary release to perform an emergency stop at any point in the turn-over process
- First push-button for starting the turn-over process
- Toggle switch for preselecting right/left rotation for the turning frame
- Second push-button for starting the turn-over process

Figure 7, Control unit

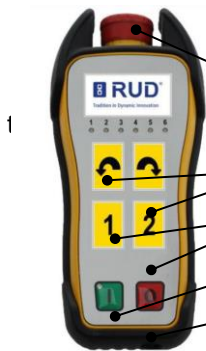

- Emergency stop button, rotary release to perform an emergency stop at any point in the
- Push-buttons for preselecting right/left rotation for the turning frame
- Push-buttons 1 and 2 for starting the turn-over process
- Green push-button for activating the control system
- Red push-button for deactivating the control system

Figure 8, Remote control

Check the switching lug and limit switch are securely in place before using the machine for the first time.

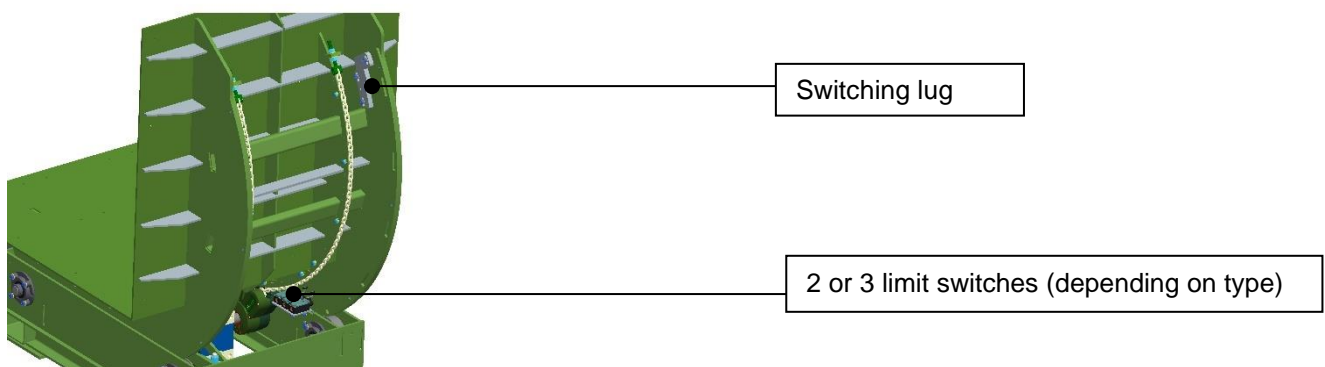

Figure 9

---

The TECDOS TM turn-over frame must be set to its middle position (position in which the machine is supplied) for commissioning. Set the toggle switch to its end position. Use both hands to operate the push-buttons. The turn-over frame moves to one of the two vertical positions shown in Figure 5. Check that the limit switches are activated on both sides by the switching lugs.

The first limit switch stops the drive motor and brings the TECDOS TM to a standstill in its end position. The second limit switch triggers an emergency stop. If a third limit position switch is installed, the system initially runs slowly.

**Caution!**

Damage and life-threatening injuries can occur if the limit switches do not operate correctly! Check that the limit switches are working correctly while the machine is rotating. If the limit switches are overrun, immediately trigger an emergency stop and notify RUD Ketten.

Move the toggle switch (control unit) / press the push-button (remote control) to the opposite end position and press the push-buttons 1 and 2 again to rotate the turn-over frame in the opposite direction until it comes to a standstill at its end position. Once again, check that the switching lugs trigger the limit switches. Keep the push-buttons pressed down during the entire rotation process, from one end position to the other. If you release one of the push-buttons, the turn-over frame will stop at the point it has just reached. Repeat this process 5 to 10 times. It should be smooth and problem-free. If problems do occur, report them to RUD Ketten immediately.

## 4.4 Accident or fault procedure

If an accident or fault occurs, stop the TECDOS TM immediately and secure it to prevent it from being accidentally switched on again. If there is an accident, apply first aid and call the emergency services. The fault must be resolved by technical staff. Do not operate the TECDOS TM again until the technical staff have authorised you to do so.

## 5. Handling the TECDOS TM

### 5.1 Loading the TECDOS TM

The TECDOS TM is usually loaded by crane. The crane must be capable of lifting at least the TECDOS TM's operating load (compare the crane manufacturer's data plate with the TECDOS TM data plate). Only authorised and designated lifting gear are to be used. Comply with all the general health and safety regulations stated in DGUV R 500 or local equivalent for working with lifting gear. Areas below suspended weights must also be secured appropriately.



**Warning!**

When loading the machine, ensure the prototype tool is positioned in the centre of the horizontal face of the turning frame and that its flat side faces the vertical face of the turning frame (see Figure 5, "Before rotation"). Failure to comply with this instruction could result in the prototype tool tilting and becoming damaged while it is rotating on the turn-over frame. In some circumstances, this uneven loading could cause the prototype tool to judder and put the prototype tool and the TECDOS TM itself at risk of tipping.

**Caution!**

The surface of the turning frame (PE/PU coating or steel plate) must not be dirty or contaminated. Dirt and contaminants could cause the prototype tool to slide or make it more susceptible to damage. Always clean the surfaces of the turning frame thoroughly and protect them against contaminants.

**Caution!**

To prevent damage and avoid burns, the temperature of the prototype tools to be used with the TECDOS TM must never exceed 40° Celsius.

- Do not use the TECDOS TM to empty out drums of liquids or gases
- Do not use the TECDOS TM as an emptying machine.
- Do not use the TECDOS TM to empty out containers of bulk material.
- To avoid risk of injury and damage, do not use the TECDOS TM to rotate round or cylindrical parts (e.g.: cable drums, coiled metal sheet or coiled wire) or parts that might not sit securely on the turn-over frame (e.g.: convex cast or forged parts or similar) unless suitable extra equipment and fixtures are also used to prevent these objects from sliding or moving unexpectedly.



**Warning!**

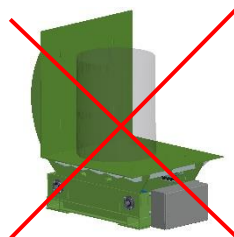

Do not use TECDOS TM machines to handle or move prototype tools that exceed the limits specified in Table 2. In case of doubt, contact RUD Ketten. It may be possible to define special regulations for particular types of use and enable the machines to be used in specific, pre-agreed conditions.

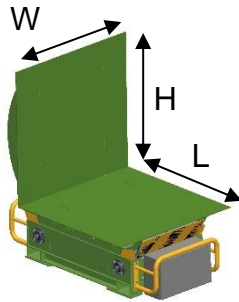

Figure 10

Size	Operating load*1)	L [mm]	H [mm]	W [mm]*2)	Unit weight [kg]
TM 08/10-5	up to 5 t	1000	1000	800	650
TM 08/13-10	up to 10 t	1.300	1.300	800	1.050
TM 13/13-10	up to 10 t	1.300	1.300	1.300	1.150
TM 15/18-16	up to 16 t	1.800	1.800	1.500	2.850
TM 20/20-20	up to 20 t	2.000	2.000	2.000	3.600

Table 2

\*1): Requirement: the load must be in contact with both table tops!

\*2): Requirements: same overhang on left and right

**Caution!**

Long, thin prototype tools and those that are generally unstable, may behave unexpectedly and tip over when being rotated with the TECDOS TM. However, these tools can be turned over if properly secured with suitable additional equipment, such as wedges and lashing straps.



**Warning!**

The prototype tool's centre of gravity should be positioned so that it lies securely on the TECDOS TM. If this is not observed, there is a risk of injury and damage to the mould and the machine. See appendix: Centre of gravity.



**Warning!**



The manufacturer accepts no liability for damage caused by improper use. All risk is assumed by the user.

## 5.2 Turn-over



**Warning!**

Before starting the turn-over process, the operator must ensure no-one else is present in the TECDOS TM's safety zone (see also Figure 6).

The turn-over process starts when the operator presses the push-buttons on the control unit and the TECDOS TM starts moving. The operator must continue pressing the push-buttons until the end of the turn-over process. If contact is interrupted, the process will also be interrupted. To resume the turn-over process, the operator must press and hold down both push-buttons again.



**Warning!**

The operator must remain at a safe distance from the TECDOS TM throughout the turn-over process. They must monitor the process carefully and be ready to interrupt it

immediately if a problem occurs. If the operator gets too close to the TECDOS TM, there is the risk that parts of their body or their clothing might get caught up in the moving parts.

## 5.3 Servicing prototype tools on the TECDOS TM

### Caution!

When cleaning and polishing prototype tools, ensure that the auxiliary materials used do not affect or damage the surfaces of the TECDOS TM (corrosion, abrasion or damage to the impact protection mat). Do not climb up onto the TECDOS TM when performing maintenance or other tasks.

## 5.4 Unloading the TECDOS TM

### Caution!

After rotating through 90°, the TECDOS TM can be unloaded. Like the loading process, the unloading process is usually performed with a crane.

Attach the crane's stop chain to the prototype tool and then carefully lift it off the TECDOS TM. Raise the prototype tool slowly and carefully to prevent it being damaged.

## 5.5 Lubricating instructions and recommended lubricants

Individual links in the chain bend and rub against each other as they pass over the wheels. This causes wear due to abrasion and leads to an increase in pitch. If the chain is lubricated regularly, it can withstand between 15 and 20 times more load cycles than an unlubricated chain. We strongly recommend that the chain is lubricated thoroughly at regular intervals.

The chain must be lubricated along its entire length prior to commissioning. To prevent premature wear, do not miss out even a single link.

The chain must not be under load when it is being lubricated. Ensure the lubricant penetrates all the chain links that are subject to wear. We recommend that lubricant is applied with a brush or as a spray.

The chains must be lubricated at regular intervals, depending on how often they are used. A chain that is used frequently will have to be lubricated more often than one that is only used occasionally. If the required lubrication schedule cannot be defined on the basis of previous experience, when starting a new task, we recommend that the chains are lubricated every 6 weeks. Lubricant should also be reapplied if the chain starts making grating noises as it runs over the wheels. This is an indication that the coating of lubricant has worn off the link.

Change-over links must be lubricated especially thoroughly. When the travel distance is constant, and the direction of movement is reversed, change-over links are the ones that come to a stop at or very close to the infeeds of the drive wheels and deflection wheels. These chain links are subjected to extremely high loads due to dynamic vibration and therefore must be lubricated thoroughly and more often to prevent premature wear.

We recommend these lubricants:

### **Optimol Viscogen KL300**

Castrol Industrie GmbH

Friedenstraße 10

81671 Munich, Germany

Silicone-free, high-viscosity synthetic lubricant. Extremely durable and resistant to hot water. Has excellent adhesive and penetrating properties. Cannot be washed away with water. Temperature-stable at application temperatures ranging between -40°C and +200°C. The highest load cycles have been achieved with this synthetic lubricating oil. Extremely suitable for use in normal industrial environments and for offshore applications. This oil can be purchased from the world-wide BP sales network and is available as a spray or in open containers.

## 5.6 Setting and tensioning the chain strands

Before using the TECDOS TM for the first time, check the tension of the two chain strands and adjust them if necessary.

Check the chain tension on the loaded and unloaded sides. No tools required. Simply pull on the chain at less than 90° to the contact surface. If you can pull the chain to the side or lift it up from the contact surface, it must be retensioned using the TECDOS chain-end attachments (Figure 11). The tension on both chain strands should be as even as possible and be tight enough to ensure the chain cannot be lifted off the contact surface (Figure 12). Then check the chain tension under load.

Check the chain tension at regular intervals, depending on how often the machine is used.

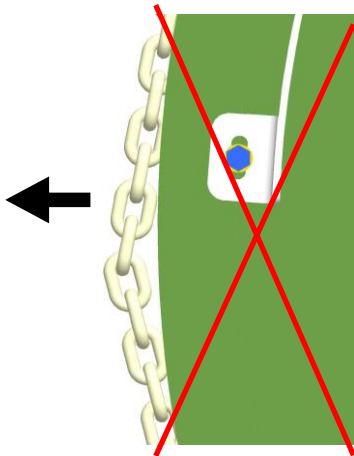

Figure 11

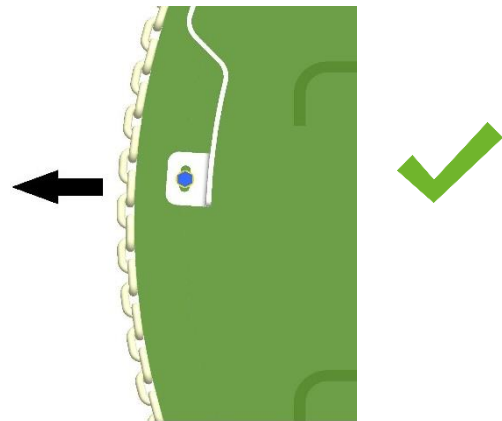

Figure 12

---

## 6. Replacing worn parts

### 6.1 Replacing the chain

To unmount the chain, rotate the turn-over frame to its middle position (V-position). Then secure the turn-over frame to prevent it from moving unexpectedly before starting work on the TECDOS TM (see section 2.3). You can also attach a 4-strand stop chain to the turn-over frame so that the chains do not hang slack in the attachment points.

Then disconnect the chain-end attachments from the drive chain. You can then use a crane to lift the turn-over frame out of the TECDOS TM. You can now thread in the new chain. Reverse the sequence of steps to assemble the machine again. Comply with the appropriate Operating Instructions for the TECDOS chain drive and the general operating instructions for TECDOS components.

### 6.2 Replacing a track wheel (support rollers) and the flanged bearings

The first part of this process is identical to the process described in section 6.1 described. The turn-over frame can be removed once the drive chain has been disconnected from the chain-end attachments. Then, undo the safety bolts on the flange bearings so that the axis and the track wheel can be removed. You can then replace the flanged bearings and the track wheel. To reassemble, perform these steps in reverse order.

**We recommend you task RUD Ketten with performing maintenance on the TECDOS TM. Our highly trained and professional Service team are always happy to help if you have any queries.**

RUD Ketten  
Rieger & Dietz GmbH u. Co. KG  
Friedensinsel  
73432 Aalen/Germany  
Tel. +49 7361 504-1457  
Fax +49 7361 504-1523  
[salesfa@rud.com](mailto:salesfa@rud.com)  
[www.rud.com](http://www.rud.com)



Centre of gravity TM 08/13-10

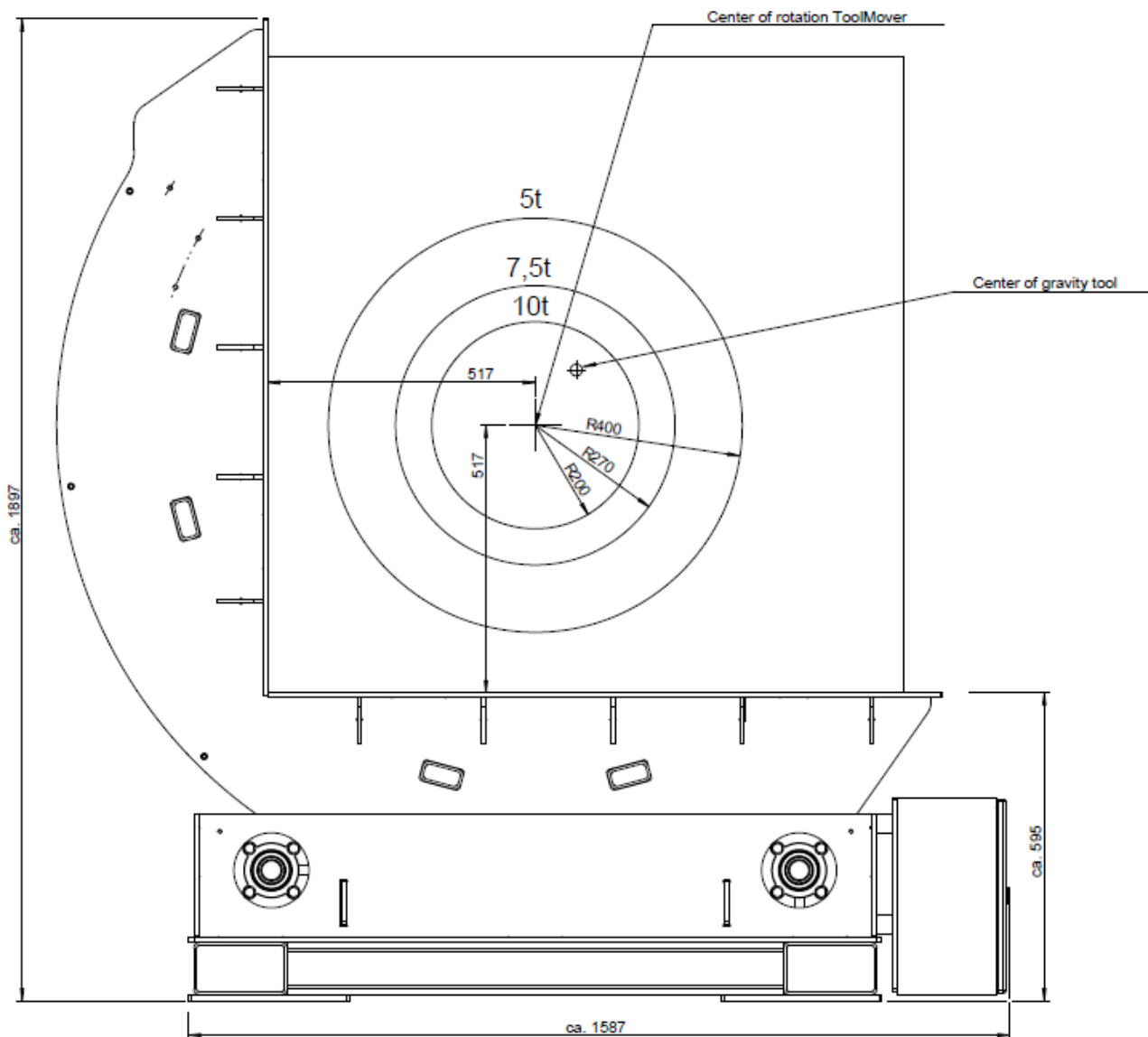

Centre of gravity TM 13/13-10

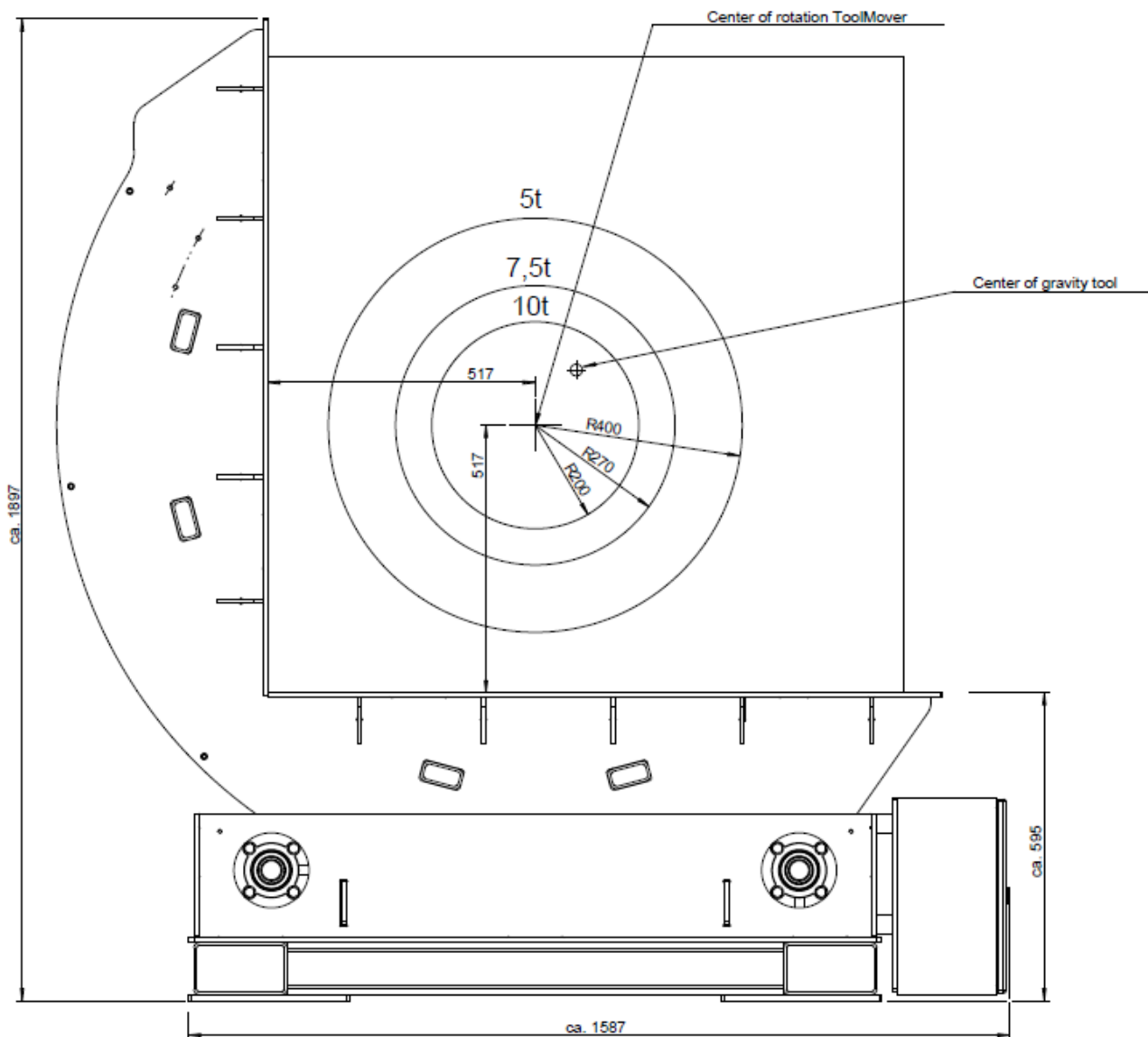

Centre of gravity TM 15/18-16

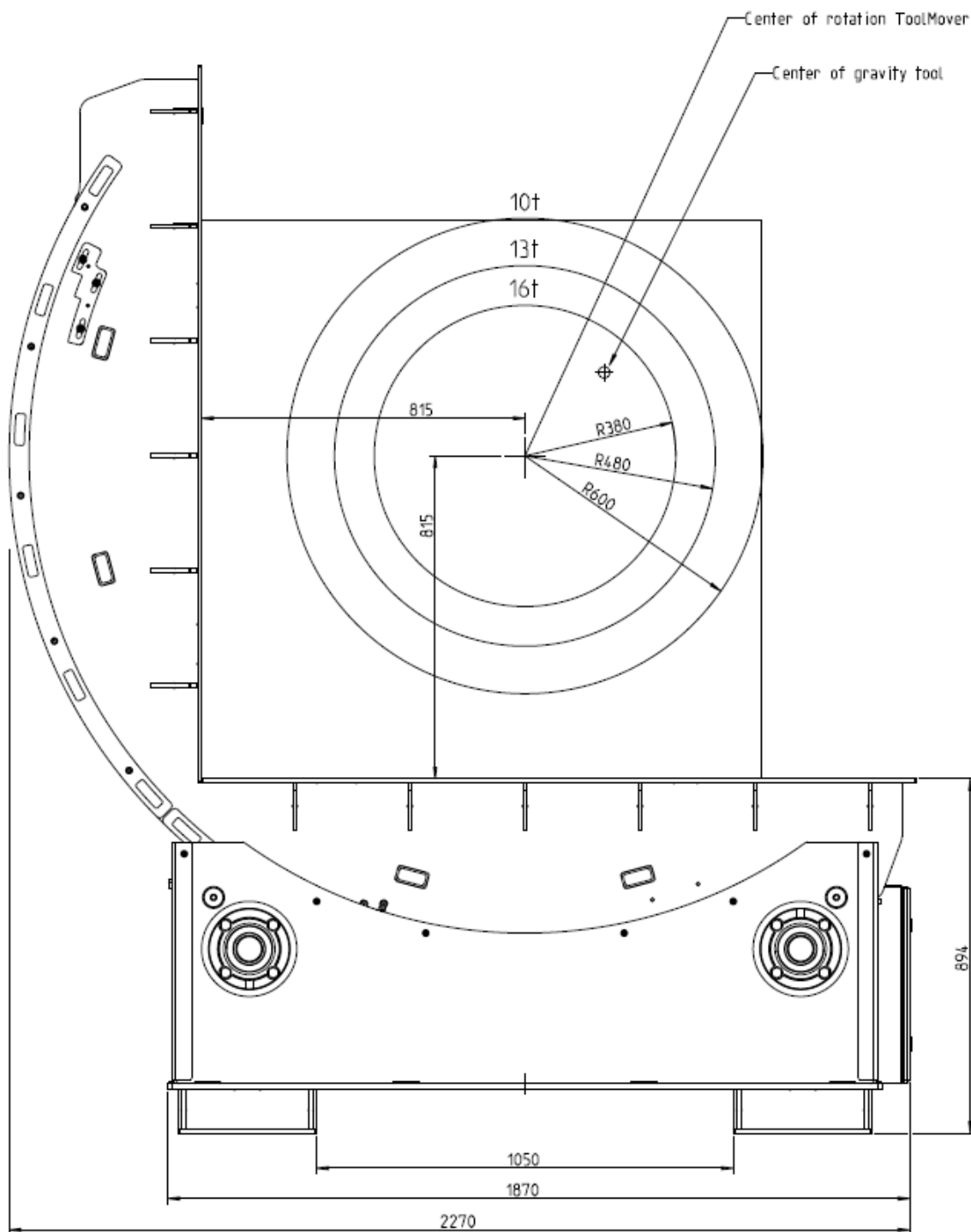

Centre of gravity TM 20/20-20

